

HIGH SAFETY PRESSURE GAUGE

The label *Trafag Industrial Components* extends the Trafag brand name to instruments manufactured by qualified partner companies.

Trafag Industrial Components complement the genuine Trafag product range to offer customers a complete portfolio from one single source.

The TMP204 Pressure Gauge Phenol case with a solid front, with full blow back.



Applications

- Oil & Gas applications
- High pressure applications
- Corrosive & Hazardous environments

Features

- Solid front with full blow back
- All stainless steel system
- Dry / liquid filled
- Light weight
- Stabilized accuracy

Reference

- ANSI B 40.100

Standard parameters	
Accuracy	Grade 2A ($\pm 0.5\%$)
Ambient temperature	-20 ... + 65°C (without dampening liquid) 10 ... + 65°C (with dampening liquid, glycerin)
Service temperature	120°C max
Pressure limits	Steady pressure up to FS value Fluctuating pressure up to 90% of FS value Short time 1.3 x FS value for range up to 100 bar Short time 1.15 x FS value for range above 100 bar
Measuring range	-1 ... 0 bar, -600 ... 0 mbar to 0 ... 1600 bar
Weld joints	TIG argon arc welding

Ordering code

		TMP204 - XX - XXX - XX - XXX - XX - XX - XX								
1. Dial size	4.5"		45							
2. Range	Refer "Range Table"			XXX						
3. Mounting pattern	Direct, Bottom connection							B0		
	Wall/Surface/Projection mounting, Bottom connection							B1		
	Panel/Front flange mounting, Lower Back connection							L1		
4. Process connection¹	1/4" NPT (M)								12N	
	1/4" BSP (M)								12B	
	3/8" BSP (M)								13B	
	1/2" BSP (M)								14B	
	M20 X 1.5 mm (M)								14M	
	1/2" NPT (M)								14N	
	3/8" NPT (M)								13N	
5. Ingress protection	IP 65								ER	
	IP 66								ES	
	IP 67								ET	
6. Execution	Dry but fillable								EB	
	Dampening liquid filled, glycerine								EG	
7. Other options	Dampening screw, Monel	EM								TC
	Dampening screw, AISI 316 SS	EN								TM
	Internal overload stop	EX								TN
	Internal vacuum stop	EY								TO
	Pointer stop on dial	EZ								TP
	Plexi glass	GB								TT
	AISI 316 SS movement	GL								XF
	Dampened movement	GM								XG
	Monel wetted parts	MN								XR
	Receiver gauge	R9								XT
	5 - point calibration certificate	TA								XB

¹⁾ For other connections, please contact factory.

²⁾ C.C. = Calibration Certificate

Specifications		
Material of construction	Sensing element	Bourdon Tube (≤ 100 bar: C - type , > 100 bar: Helical)
	Case & Ring material	Phenolic resin
	Bourdon tube & Shank	AISI 316L SS
	Movement mechanism	AISI 304 SS
	Dial	Aluminum, black graduation on white background
	Pointer	Micro-zero adjustable, aluminum, black powder coated
	Window	Shatterproof safety glass
	Blow off disc	Phenolic resin
	Gaskets & Filling plug	Neoprene/NBR
Standard specifications	Dial size	4.5"
	Range	-1 ... 0 to 0 ... 1600 bar
	Mounting pattern	Direct, Bottom connection
	Process connection	1/2" NPT (M) / 1/2" BSP (M)
	Ingress protection	IP 65
	Execution	Dry but fillable
Standard specifications : dampening liquid filled, glycerin	Window	Shatterproof safety glass
	Dampening liquid	Glycerin 99.7% [Service temperature up to 65°C]
Temperature effect	When temperature of the measuring system deviates from reference temperature (+20°C) max error $\pm 0.4\%$ / 10K of true scale value.	

Dimensions - All dimensions are in mm

Type B0, B1

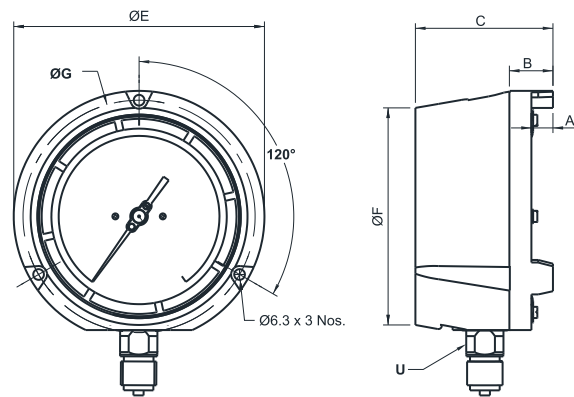

DN	A	B	C	ØE	ØF	G	U	Weight (grams)
115	12,5	26	82	149	129	137	A/F-22	828

Type L1

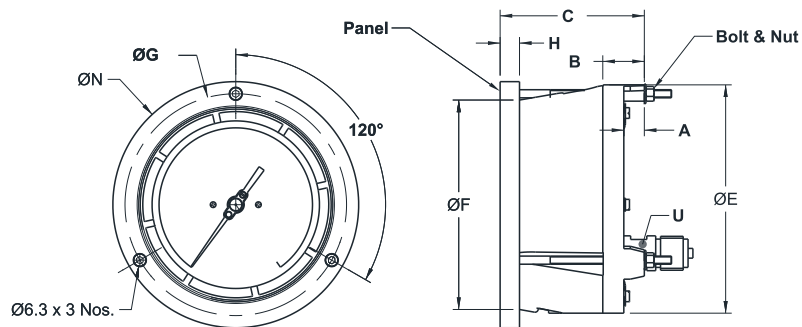

DN	A	B	C	ØE	ØF	G	H	ØN	U	Weight (grams)
115	12,5	26	82	149	129	137	12	152	A/F-17	933

Standard Ranges				Standard Ranges		Standard Ranges		Standard Ranges		Standard Ranges	
RANGE	bar	Kg/cm ²	bar/psi	RANGE	psi	RANGE	kPa	RANGE	MPa	RANGE	mbar
0 ... 0.6	B01	K01	N01	0 ... 10	S01	0 ... 60	E01	-	-	-600 ... 0	B00
0 ... 1	B02	K02	N02	0 ... 15	S02	0 ... 100	E02	0 ... 0.1	M02	-	-
0 ... 1.6	B03	K03	N03	0 ... 25	S03	0 ... 160	E03	0 ... 0.16	M03	-	-
0 ... 2.5	B05	K05	N05	0 ... 35	S05	0 ... 250	E05	0 ... 0.25	M05	-	-
0 ... 4	B06	K06	N06	0 ... 60	S06	0 ... 600	E06	0 ... 0.4	M06	-	-
0 ... 6	B07	K07	N07	0 ... 90	S07	0 ... 600	E07	0 ... 0.6	M07	-	-
0 ... 7	B08	K08	N08	0 ... 100	S08	0 ... 700	E08	0 ... 0.7	M08	-	-
0 ... 10	B09	K09	N09	0 ... 150	S09	0 ... 1000	E09	0 ... 1	M09	-	-
0 ... 16	B11	K11	N11	0 ... 235	S11	0 ... 1600	E11	0 ... 1.6	M11	-	-
0 ... 25	B13	K13	N13	0 ... 365	S13	0 ... 2500	E13	0 ... 2.5	M13	-	-
0 ... 40	B16	K16	N16	0 ... 600	S16	0 ... 4000	E16	0 ... 4	M16	-	-
0 ... 60	B17	K17	N17	0 ... 870	S17	0 ... 6000	E17	0 ... 6	M17	-	-
0 ... 70	B18	K18	N18	0 ... 1000	S18	0 ... 7000	E18	0 ... 7	M18	-	-
0 ... 100	B19	K19	N19	0 ... 1500	S19	0 ... 10000	E19	0 ... 10	M19	-	-
0 ... 160	B21	K21	N21	0 ... 2300	S21	0 ... 16000	E21	0 ... 16	M21	-	-
0 ... 250	B24	K24	N24	0 ... 3600	S24	0 ... 25000	E24	0 ... 25	M24	-	-
0 ... 400	B27	K27	N27	0 ... 6000	S27	0 ... 40000	E27	0 ... 40	M27	-	-
0 ... 600	B29	K29	N29	0 ... 8700	S29	0 ... 60000	E29	0 ... 60	M29	-	-
0 ... 700	B30	K30	N30	0 ... 10000	S30	0 ... 70000	E30	0 ... 70	M30	-	-
0 ... 1000	B31	K31	N31	0 ... 15000	S31	-	-	0 ... 100	M31	-	-
0 ... 1600	B34	K34	N34	0 ... 23200	S34	-	-	0 ... 160	M34	-	-
-1 ... 0	B37	K37	N37	-30 ... 0 ¹	S37	-100 ... 0	E37	-0.1 ... 0	M37	-	-
-1 ... 0.6	B38	K38	N38	-30 ... 10 ¹	S38	-100 ... 60	E38	-0.1 ... 0.06	M38	-	-
-1 ... 1.5	B39	K39	N39	-30 ... 20 ¹	S39	-100 ... 150	E39	-0.1 ... 0.15	M39	-	-
-1 ... 3	B42	K42	N42	-30 ... 45 ¹	S42	-100 ... 300	E42	-0.1 ... 0.3	M42	-	-
-1 ... 5	B43	K43	N43	-30 ... 75 ¹	S42	-100 ... 500	E43	-0.1 ... 0.5	M43	-	-
-1 ... 9	B45	K45	N45	-30 ... 130 ¹	S45	-100 ... 900	E45	-0.1 ... 0.9	M45	-	-
-1 ... 15	B47	K47	N47	-30 ... 220 ¹	S47	-100 ... 1500	E47	-0.1 ... 1.5	M47	-	-
-1 ... 24	B49	K49	N49	-30 ... 350 ¹	S49	-100 ... 2400	E49	-0.1 ... 2.4	M49	-	-

General notes

- Other scales & measurement units are available.
- Equivalent scales available in kg/cm², psi, kPa, MPa, bar/psi, kPa/bar, kPa/psi or any other special scales.
- Primary scales shall be in "BLACK" and secondary scales shall be "RED".
- Special scales, custom dial designs, OEM/private logo printing is available, details contact our marketing team.
- Any other range codes which are not available in the list shall be confirmed by factory.

Technical note

- In compound ranges, negative pressures are marked in In Hg, hence for example for -1 to 1 bar the corresponding scale shall be -30"Hg to 15 psi.

Additional information			
Documents	Data sheet	H20008	www.trafag.com/H20008
	Instructions	H21001	www.trafag.com/H21001