

INDUSTRIAL THERMOMETER

The label *Trafag Industrial Components* extends the Trafag brand name to instruments manufactured by qualified partner companies.

Trafag Industrial Components complement the genuine Trafag product range to offer customers a complete portfolio from one single source.

The TMT703 Inert gas filled Industrial Thermometer in High Case Version is used in general industrial applications with extreme media temperatures from -200°C up to +700°C where electrical contacts are required.



Applications

- Liquid & gaseous mediums
- Corrosive environments
- Oil & Gas applications
- Chemical & Petrochemical

Features

- Inert gas filled expansion
- Filled versions
- Bi-metal compensation

Reference

- EN 13190

02/2018

Data sheet HH2002.1b

Standard parameters	
Accuracy	CL 1.0 (Class 1)
Permissible ambient temperature	-40 ... +60°C with/without dampening
Storage & Transport temperature	-50 ... +70°C without liquid dampening -20 ... +60°C with liquid dampening
Over range limits	110% full scale
Stem pressure rating	25 bar (Without thermowell)
Weld joints	TIG argon arc welding
Measuring range	-200 ... 0 to 0 ... 700°C -330 ... 0 to 0 ... 1290°F

Ordering code

		TMT703 - XX - XXX - XX - XXX - XX - XXXX - XX - XX - XX - XX - XXXXX - XX - XX - XX													
1. Dial size	100 mm / 4"	04													
	150 mm / 6"	06													
2. Range ¹	Refer "Range Table" ²		XXX												
3. Mounting pattern	Direct, Bottom connection	B0	Every Angle mounting, Centre Back connection		R1										
	Wall/Surface/Projection mounting, Bottom connection	B1	Lower, Back connection		L0										
		B2	Panel/Front flange mounting, Lower Back connection		L1										
	2" Pipe/Yoke mounting, Bottom connection	B2	Panel/bracket mounting, Lower Back connection		L2										
	Centre Back connection	R0													
4. Stem diameter	6,0 mm	M60	¼" (6,35 mm)		I14										
	8,0 mm	M80	9,5 mm		M95										
	10 mm	M10	12 mm		M12										
5. Ingress protection	IP 65	ER	IP 67		ET										
	IP 66	ES													
6. Stem length	Up to 1,500 mm				XXXX										
7. Process connection type	Fixed connection	KX		Swivel / Revolving connection		BW									
	Adjustable connection	KW		Without		99									
8. Process connection ¹	½" NPT (M)	14N	M27 X 2.0 mm (M)	16M	¾" NPT (F)	05N									
	¼" NPT (M) ⁴	12N	½" BSP (M)	14B	Without	099									
	M20 X 1.5 mm (M)	14M	¼" BSP (M) ⁴	12B	Special ¹	ZZZ									
	¾" NPT (M)	15N	3/8" BSP (M) ⁵	13B											
	½" NPT (F)	04N	¾" BSP (M)	15B											
9. Assembly	Direct (Stem type)	B8		Remote (Capillary type) ³		B9									
10. Capillary	AISI 304SS	OU		AISI 316 SS		OV									
11. Armour	AISI 304 SS	OX		AISI 316 SS		OY		PVC (Ambient max. 60°C)		OZ					
12. Remote mounting length	250 mm up to 25,000 mm										XXXXX				
13. Switch category	Precision contacts (Magnetic)												RS		
14. Electric contact	Break contact (1NC)	CD1		1 Make + 1 Break (1NO + 1NC)		CD6									
	Make contact (1NO)	CD2		SPDT		CD7									
	2 x Break contact (2NC)	CD3		DPDT		CD8									
	2 x Make contact (2NO)	CD4													
	1 Break + 1Make (1NC + 1NO)	CD5													
15. Other options	Case & Ring in AISI 316 SS (B0)	BA		Case & Ring in AISI 316 SS (L2)		BM		Material test certificate 2.2		TM					
	Case & Ring in AISI 316 SS (B1)	BB		Dampening liquid filled, dielectric oil		EK		SS tag plate, AISI 304 SS		XF					
	Case & Ring in AISI 316 SS (B2)	BC		Helium gas filled system		E9		SS tag plate, AISI 316 SS		XG					
	Case & Ring in AISI 316 SS (R0)	BG		6 pin, M20 x 1,5mm connector		G6		Dial tag marking		XT					
	Case & Ring in AISI 316 SS (R1)	BH		Earth terminal		G7		Custom designed dial		XR					
	Case & Ring in AISI 316 SS (L0)	BK		Rubber parts, Viton		RA									
	Case & Ring in AISI 316 SS (L1)	BL		5 - point calibration certificate		TA									

¹ For other ranges, connections, please contact factory.

² Equivalent scales available in °F, °C/°F, °F/°C.

³ While selecting capillary, Bottom connections are supplied with wall mounting flange & Back

connection are with Panel / front flange.

⁴ ¼" connections are available up to 1/4" (6.35 mm) stem diameter only.

⁵ 3/8" connections are available up to 10 mm stem diameter only.

Specifications		
Material of construction	Sensing element	Inert Gas Filled sensor bulb
	Case & Ring material	AISI 304 SS
	Stem & Process connection material	AISI 316 SS
	Dial	Aluminum, black graduation on white background
	Pointer	Micrometer zero adjustable, aluminum, black powder coated
	Gaskets	NBR
	Window	Shatterproof safety glass
Standard specifications	Dial size	DN100 / DN150
	Range	-200 ... 0 to 0 ... +700°C / -330 ... 0 to 0 ... +1290°F
	Mounting pattern	Direct Bottom connection
	Stem size	6,0 mm
	Ingress protection	IP 65
	Stem length	70 mm to 2,000 mm*
	Assembly	Direct
	Process connection type	Adjustable connection
	Process connection	½" NPT (M) / ½" BSP (M)
	Electric contact	Double; Break contact + Make contact
	Electrical termination	4 pin PG 13,5 connector
Standard specifications : dampening liquid filled, dielectric oil	Gaskets & Filling plugs	NBR
	Dampening liquid	Dielectric oil
* Depending on range & stem diameter		

Dimensions - All dimensions are in mm

Mounting pattern: B0, High case type

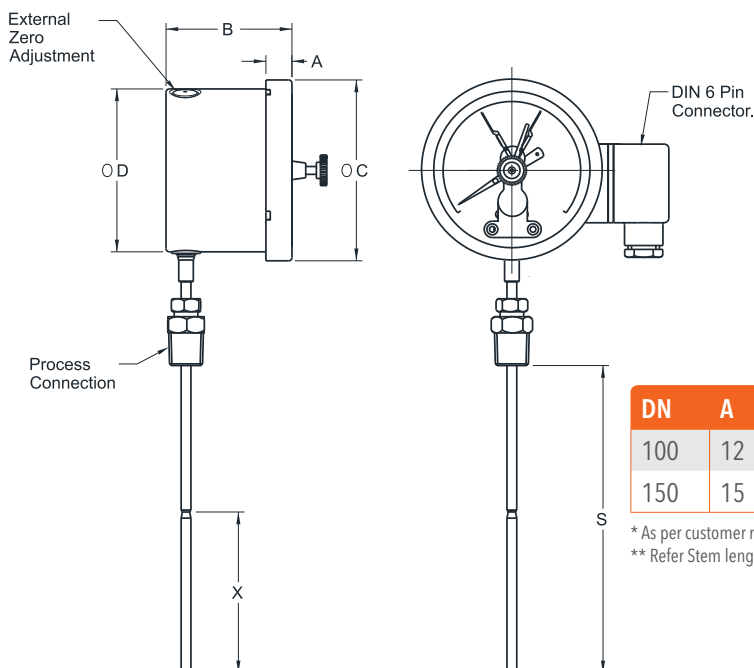

DN	A	B	ØC	ØD	S	X
100	12	91	111	100	*	**
150	15	91	161	149	*	**

* As per customer requirement.
 ** Refer Stem length chart table.

Mounting pattern: B1, High case type

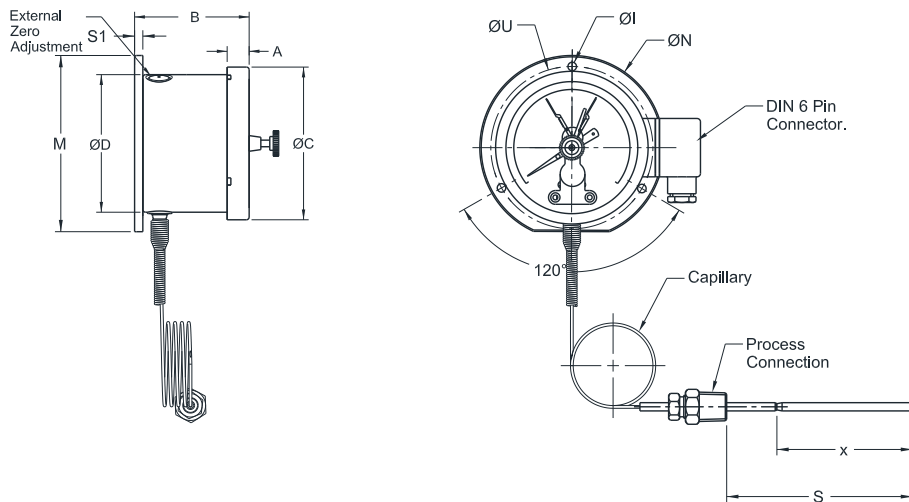

DN	A	B	ØC	ØD	ØI	ØN	M	S1	ØU	S	X
100	12	98	111	100	6	134	128	6	118	*	**
150	15	98	161	149	6	186	172,4	6	168	*	**

* As per customer requirement.
 ** Refer Stem length chart table.

Mounting pattern: R0, High case type

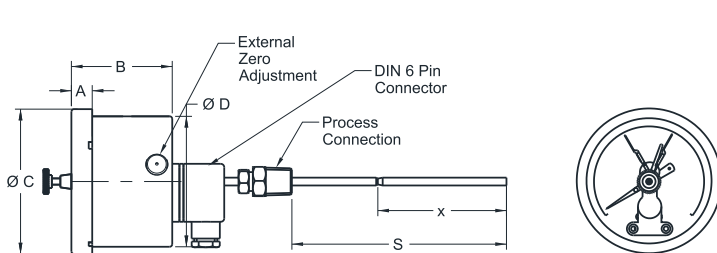

Mounting pattern: R1, High case type

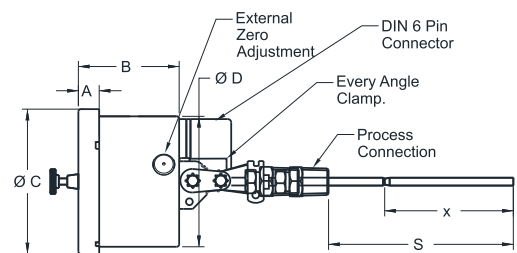

Mounting pattern: L0, High case type

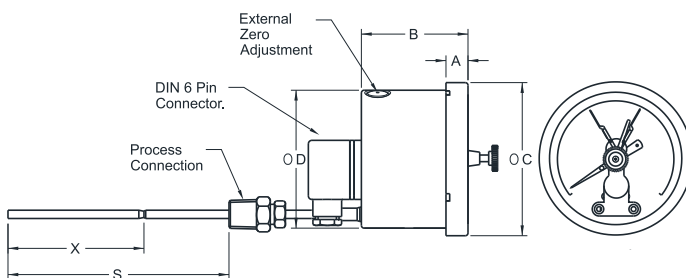

DN	A	B	ØC	ØD	S	X
100	12	91	111	100	*	**
150	15	91	161	149	*	**

* As per customer requirement.
 ** Refer Stem length chart table.

Mounting pattern: L1, High case type

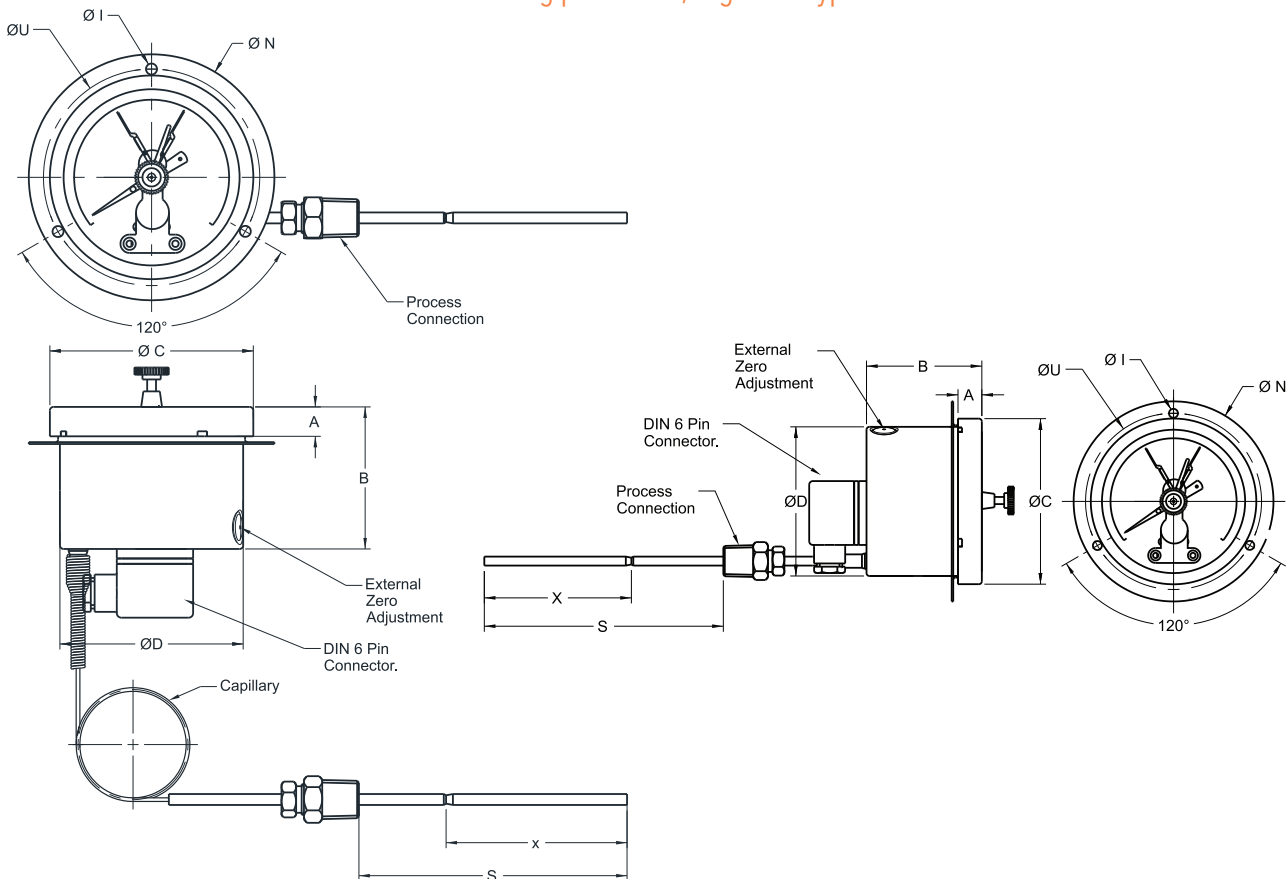

DN	A	B	$\varnothing C$	$\varnothing D$	$\varnothing I$	$\varnothing N$	$\varnothing U$	S	X
100	12	91	111	100	6	134	118	*	**
150	15	91	161	149	6	186	168	*	**

* As per customer requirement.
 ** Refer Stem length chart table.

Stem length chart

Stem/Sensor Size (mm)	(x) Sensor Length (mm)	(S) Minimum stem Length (mm)
Rigid stem type Inert Gas Thermometer		
Capillary type Inert Gas Thermometer (≤ 10 m)		
6 / 1/4"	200	240
8 / 9,5	120	160
10	90	130
12/14	70	110
Capillary type Inert Gas Thermometer (>10 m up to 25 m)		
8 / 9,5	170	210
10	140	180
12 / 14	90	130

- Capillary compensation is preferred for all capillary inert gas thermometers, if capillary length is above 6 meter.
- For other reduced length, contact factory before ordering.

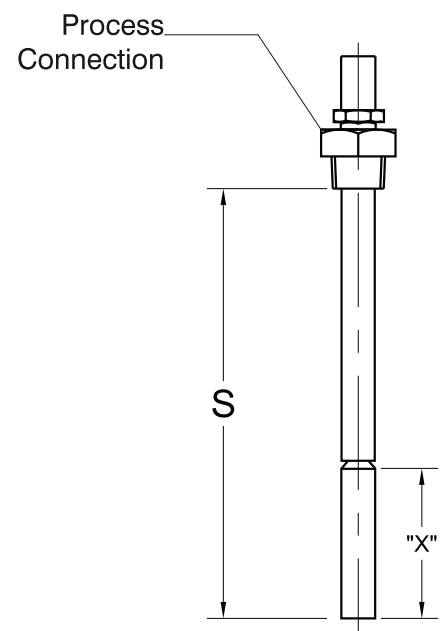

Range table (°C)	Code
-20 ... +40	C01
-20 ... +60	C02
-20 ... +80	C03
-20 ... +100	C04
-20 ... +120	C05
-20 ... +180	C06
-30 ... +50	C07
-30 ... +70	C08

Range table (°C)	Code
-40 ... +40	C09
-40 ... +60	C10
-50 ... +100	C11
-100 ... +60	C12
0 ... 50	C13
0 ... 60	C14
0 ... 80	C15
0 ... 100	C16

Range table (°C)	Code
0 ... 120	C17
0 ... 150	C18
0 ... 160	C19
0 ... 200	C20
0 ... 250	C21
0 ... 300	C22
0 ... 400	C23
0 ... 500	C24

Range table (°C)	Code
0 ... 600	C25
0 ... 650	C26
50 ... 650	C27
100 ... 600	C28
100 ... 700	C29

Electrical contact details

Switch type	Contacts	Action	Rating	Code
Normally closed (1NC)	Single	Break contact	230VAC/1A; 48VDC/0.5A	CD1
Normally open (1NO)	Single	Make contact	230VAC/1A; 48VDC/0.5A	CD2
Normally closed (2NC)	Double	Break contact	230VAC/1A; 48VDC/0.5A	CD3
Normally open (2NO)	Double	Make contact	230VAC/1A; 48VDC/0.5A	CD4
Normally closed + Normally open (1NC+1NO)	Double	Break contact + Make contact	230VAC/1A; 48VDC/0.5A	CD5
Normally open + Normally closed (1NO+1NC)	Double	Make contact + Break contact	230VAC/1A; 48VDC/0.5A	CD6
SPDT	Single		230VAC/1A; 48VDC/0.5A	CD7
DPDT	Double		230VAC/1A; 48VDC/0.5A	CD8

Codes starts with "CD" denomination are magnetic contacts and "CI" are Inductive contacts.

Additional information

Documents	Data sheet	H20021	www.trafag.com/H20021
	Instructions	H21019	www.trafag.com/H21019