

FLOAT LEVEL SWITCH

The label *Trafag Industrial Components* extends the Trafag brand name to instruments manufactured by qualified partner companies.

Trafag Industrial Components complement the genuine Trafag product range to offer customers a complete portfolio from one single source.

The principle of operation of these instruments is based on the drive of one or more magnetic reed contacts, placed inside of the measuring rod, by one or more floats. Up to 6 floats with individual switchpoints are available for comprehensive monitoring of the liquid level.



Applications

- Water treatment
- Machine tools
- Mobile hydraulics
- Food & Beverages
- Chemical & Pharmaceutical



Features

- Up to 6 switch points
- Minimum degree of protection IP65
- Optional temperature sensor PT1000 or thermostat
- Potted electrical contacts

Reference

- EN61010-1

04/2026

Data sheet H20041g

Standard parameters			
Type	TFSO	TFSS	TFSP / D / V
Floats	Spansil - Butadiene - Acrylonitrile Copolymer	Stainless steel AISI316	PVDF - PP - PVC
Ambient temperature	-30 ... + 55°C	-30 ... +55°C	-30 ... +55°C
Media temperature	Up to 105°C, optional 120°C	Up to 105°C, optional 150°C or 180°C	Up to 130°C (PVDF) Up to 90°C (PP) Up to 60°C (PVC)
Working pressure ¹	20 bar max	50 bar max	6 bar (PVDF or PVC) max 3 bar (PP) max

¹ Depend of type of float.

Ordering code

				TFS	-	X	-	X	-	XXX	-	XX	-	XXXX	-	XXX	-	XX	-	X	-	X	-	X	-	XX			
1. Float and Stem Material¹	Brass and Spansil	O	PVDF	D																									
	AISI316 L	S	PVC	V																									
	PP	P																											
2. Number of contacts	Nr. contact (special versions)	X	4 contacts	4																									
	1 contacts	1	5 contacts	5																									
	2 contacts	2	6 contacts	6																									
	3 contacts	3																											
3. Floats²⁻⁵	<i>Float material</i>	<i>Type</i>	<i>Dimension (are in mm)</i>		<i>Float material</i>	<i>Type</i>	<i>Dimension (are in mm)</i>																						
	Spansil	TFSO	Ø 30x20	B20	PVDF	PVDF	Ø 20x25	F20																					
			Ø 20x28	B28			Ø 25x25	F25																					
			Ø 44x50	B44			Ø 49x53	F49																					
			Ø 30x45	B45			PP	TFCP	Ø 20x25	P20																			
	AISI316 L	TFSS	Ø 30x32	S29	Ø 49x53	P49																							
			Ø 40x52	S40	PVC	TFCV	Ø 49x53	V49																					
			Ø 41x35	S41																									
			Ø 52	S52			Special float ⁸	Z99																					
			Ø 52x68	S53																									
		Ø 100	S10																										
	4. Electrical contacts⁶	SPST, High voltage type	03	SPDT, High voltage and current	07																								
SPST, High current type		04	SPDT, Low voltage and current	7D																									
5. Stem length⁵	"L0" max 2000 mm													XXXX															
6. Process connection³	Inside, G 3/8" m	G06	G 3/4 m, mounting from outside	G34																									
	Inside, 1/8" NPT m	N06	3/4 NPT m, mounting from outside	N34																									
	Inside, G 1/4" m	G08	Outside, G 2" m	G50																									
	Inside, 1/4" NPT m	N08	Outside, 2" NPT m	N50																									
	Inside, G 1/2" m	G15	Flange type DIN (to specify dimension for ex. 2")	DN1																									
	Inside, 1/2" NPT m	N15	Flange type ANSI (to specify dimension for ex. DN40 PN16)	DN2																									
	Flange type EN (to specify PN)	DN3	Flange 6 holes on Ø60 mm in brass	FOH																									
	Outside, G 1" m	G25	Flange 6 holes on Ø60 mm in SS	FSH																									
	Outside, 1" NPT m	N25	Bilge - Bracket connection	B99																									
	Outside, G 1 1/2" m	G40	Special process connection ⁹	X99																									
	Outside, 1 1/2" NPT m	N40																											
	7. Electrical connection⁴⁻⁷	Housing Max 5 terminals	W1	Cable gland brass including 3 m PVC cable	P1	PVC Cable L=3 m	C1																						
		Housing Max 18 terminals	W2	Cable gland brass including 3 m SILICON cable	P2	SILICON Cable L=3 m	C2																						
DIN43650 A (29x29 mm)		S1			Bilge armoured cable 3x0.75 - PVC - 10m	A1																							
Special ¹⁰		C9	Bilge armoured cable 3x0.75 - PVC - 5m	A5																									
8. Temperature class²	Standard	L	Medium	M	High ¹⁶	H																							
9. Wiring⁷	Separately wired contacts	I	Common wired contacts	C																									
10. Contact status¹²	Normally open (NO)	1	Normally closed (NC)	2	SPDT	3																							
11. Options	PT1000 EN60751 IEC751 Class A	PT	Other options ¹¹	ZZ																									
	PT100 EN60751 IEC751 Class A	PA	Bilge ¹⁵	BL																									
	TRM (thermostat). Range: +40 ... +120°C (10°C step); Precision ±5% FS; Differential 10°C ±4°C	TR																											
	Flexible version with PA11 hose extension ¹³	FL																											
	Number of contacts (only with option FL)	YY																											
	Shipbuilding version - EUROMR ¹⁴	MR																											

¹⁾ See table Materials

²⁾ See table Floats

³⁾ See table Process Connections

⁴⁾ See table Electrical Connections

⁵⁾ See table Dimensions

⁶⁾ See table Electrical Contacts

⁷⁾ See table Wiring

⁸⁾ For other floats, please contact factory

⁹⁾ For other process connections, please contact factory

¹⁰⁾ For other electrical connections, please contact factory

¹¹⁾ For other options, please contact factory

¹²⁾ If we have more contacts, in our code is necessary to specify the different contact status for each contact.

¹³⁾ Only for option FL choose

¹ «X» (section 2),

² Number of contacts «YY» (section 11)

¹⁴⁾ Not available with PVC/PP/PVDF

¹⁵⁾ Bilge version requires code TFS-S-1-S41-07-0142-B99-A1/A5-L-I-2-MR-BL. See table BILGE

¹⁶⁾ In combination with cooling tower

Material

Tab. 1

Type	Stem	Float	Process connection	Flange
TFSO x B xx	Brass	Spansil	Brass	Brass
TFSS x S xx	AISI316	AISI316	AISI316	AISI316
TFSD x F xx	PVDF	PVDF	PVDF	PVDF
TFSP x P xx	PP	PP	PP	PP
TFSV x V xx	PVC	PVC	PVC	PVC

Floats TFSSO

Tab. 2

				
Code	B20	B28	B45	B44
Material	Spansil	Spansil	Spansil	Spansil
Dimension (mm)	Ø30x20	Ø20x28	Ø30x45	Ø44x50
Specific gravity (kg/dm ³)	0,4	0,4	0,35	0,45
Max. Pressure (bar)	20	20	20	20
Media temperature standard code "L"	105°C	105°C	105°C	105°C
Media temperature medium code "M"	120°C	120°C	120°C	120°C







Floats TFSS

Tab. 2

							
Code	S29	S32	S40	S41	S52	S53	S10
Material	AISI316	AISI316	AISI316	AISI316	AISI316	AISI316	AISI316
Dimension (mm)	Ø30x32	Ø30x32	Ø40x52	Ø41x35	Ø52x68	Ø52	Ø100
Specific gravity (kg/dm ³)	0,75	0,55	0,78	0,82	0,65	0,7	0,6
Max. Pressure (bar)	30	10	15	10	50	40	15
Media temperature standard code "L"	105°C	105°C	105°C	105°C	105°C	105°C	105°C
Media temperature medium code "M"	150°C	150°C	150°C	150°C	150°C	150°C	150°C

Floats TFSP / D / V

Tab. 2

						
Code	F20	F25	F49	P20	P49	V49
Material	PVDF	PVDF	PVDF	PP	PP	PVC
Dimension (mm)	Ø20x25	Ø25x25	Ø49x53	Ø20x25	Ø49x53	Ø49x53
Specific gravity (kg/dm³)	0,7	0,65	0,8	0,5	0,45	0,7
Max. Pressure (bar)	6	6	6	3	3	6
Media temperature standard code "L"	130°C	130°C	130°C	90°C	90°C	60°C

Process connection

Tab. 3

CODE	PROCESS CONNECTION	TFSO						TFSS				TFSP / D / V					
		B13	B15	B20	B28	B45	B44	S29	S41	S53	S10	F20	F25	F49	P20	P49	V49
G06	G ⅜ m, mounting from inside	✓	✓	✓		✓	✓	✓	✓	✓	✓	✓	✓	✓	✓	✓	✓
N06	⅜ NPT m, mounting from inside	✓	✓	✓		✓	✓	✓	✓	✓	✓	✓	✓	✓	✓	✓	✓
G08	G ¼ m, mounting from inside	✓	✓	✓		✓	✓	✓	✓	✓	✓	✓	✓	✓	✓	✓	✓
N08	¼ NPT m, mounting from inside	✓	✓	✓		✓	✓	✓	✓	✓	✓	✓	✓	✓	✓	✓	✓
G15	G ½ m, mounting from inside	✓	✓	✓		✓	✓	✓	✓	✓	✓	✓	✓	✓	✓	✓	✓
N15	½ NPT m, mounting from inside	✓	✓	✓		✓	✓	✓	✓	✓	✓	✓	✓	✓	✓	✓	✓
G25	G 1" m, mounting from outside		✓	✓				✓				✓	✓		✓		
N25	1" NPT m, mounting from outside		✓									✓	✓		✓		
G40	G 1 ½" m, mounting from outside			✓		✓	✓	✓	✓								
N40	1 ½" NPT m, mounting from outside			✓		✓		✓	✓								
G34	G ¾ m, mounting from outside				✓												
N34	¾ NPT m, mounting from outside				✓												
G50	G 2" m			✓		✓	✓	✓	✓					✓		✓	✓
N50	2" NPT m			✓		✓	✓	✓	✓					✓		✓	✓
DN1	Flange type DIN			✓		✓	✓	✓	✓	✓				✓		✓	✓
DN2	Flage type ANSI			✓		✓	✓	✓	✓	✓				✓		✓	✓
FOH	Flange 6 hole on Ø60mm in brass		✓	✓		✓						✓	✓		✓		
FSH	Flange 6 hole on Ø60mm in SS							✓									

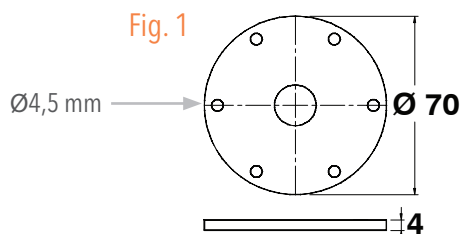

FOH - FSH
6 holes on Ø60 mm

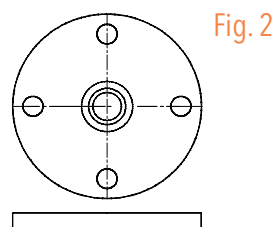

DN = DIN - ANSI Flanges

Flanges available

DIN type	ANSI type
DN25 PN6 or PN16 or PN40	1" ANSI 150# RF or 300# RF or 600# RF
DN50 PN6 or PN16 or PN40	2" ANSI 150# RF or 300# RF or 600# RF
DN80 PN6 or PN16 or PN40	3" ANSI 150# RF or 300# RF or 600# RF
DN125 PN6 or PN16 or PN40	4" ANSI 150# RF or 300# RF or 600# RF

Electrical Connection

Tab. 4

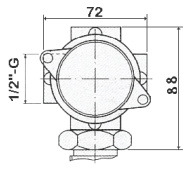
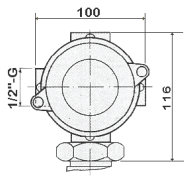
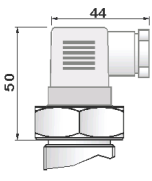
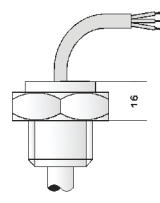
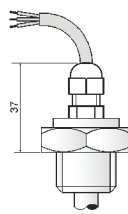
Code	W1	W2	S1	C1/C2	P1/P2
Dimension (mm)					
IP Rating	IP65	IP65	IP65	IP65	IP68
Max No of wires	5	18	3	12	12
Material	Die Cast Aluminium	Die Cast Aluminium	Plastic (Polyamide + Fiber glass)	PVC (max105°C) or Silicon (max150°C)	Cable gland brass Cable PVC (max 105°C) or SILICON (max 150°C)
Ambient temperature	-30...+55°C	-30...+55°C	-30...+55°C	-30...+55°C	-30...+55°C

Dimension (mm)

Tab. 5

Code	B13	B15	B20	B28	B45 ¹	B45 ²	B44	S29	S41	S53	S10
A	20	15	15	20	30	35	35	20	30	35	60
A1	35	30	30	35	45	50	55	40	50	55	
B	25	25	20	25	35	40	40	25	35	40	70
C	-	35	40	45	65	75	75	45	65	75	125

Code	F20	F25	F49	P20	P49	V49				
A	20	20	40	20	40	40				
A1	35	35	60	35	60	60				
B	25	25	40	25	40	40				
C	50	50	80	50	80	80				

¹With contact type 3

²With contacts type 4 | 7

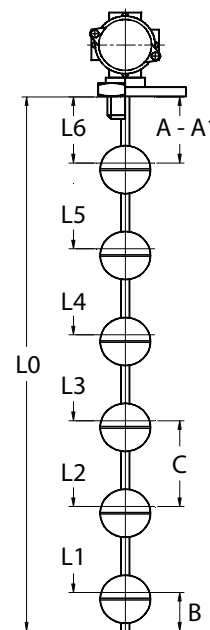

A = Flanged connection
A1 = Threaded connection
L0 = max length 2000 mm

Electrical contacts

Tab. 6

Type	Power	AC	DC
SPST 03	70 VA / 50 W	300 VAC, 0.5 A	350 VDC, 0.7 A
SPST 04	80 VA / W	250 VAC, 1.3 A	250 VDC, 1.3 A
SPDT 07	60 VA / W	230 VAC, 1 A	230 VDC, 1 A
SPDT 7D	20 VA / W	150 VAC, 0.5 A	150 VDC, 0.5 A

Max. no. of contacts

Tab. 6

Type	TFSO						TFSS				TFSP / D / V					
	B13	B15	B20	B28	B45	B44	S29	S41	S53	S10	F20	F25	F49	P20	P49	V49
SPST 3	1	6	6	4	6		6				6	6		6		
SPST 4					4	6		6	6				6		6	6
SPDT 7					3	6		6	6	6			6		6	6
SPDT 7D			6	3			4				4	6		4		

Wiring

Tab. 7					
No. of switches	Contacts ¹	Status	No. of wires standard	Electrical connection standard	Electrical connection with option (PT or TR) ²
1	I	NO	2	All type of electrical connection	W1, W2, C1, C2, P1, P2
		NC	2	All type of electrical connection	W1, W2, C1, C2, P1, P2
		SPDT	3	All type of electrical connection	W1, W2, C1, C2, P1, P2
	C	NO	3	All type of electrical connection	W1, W2, C1, C2, P1, P2
		NC	3	All type of electrical connection	W1, W2, C1, C2, P1, P2
		SPDT	3	All type of electrical connection	W1, W2, C1, C2, P1, P2
2	I	NO	4	W1, W2, C1, C2, P1, P2	W2, C1, C2, P1, P2
		NC	4	W1, W2, C1, C2, P1, P2	W2, C1, C2, P1, P2
		SPDT	6	W2, C1, C2, P1, P2	W2, C1, C2, P1, P2
	C	NO	3	All type of electrical connection	W1, W2, C1, C2, P1, P2
		NC	3	All type of electrical connection	W1, W2, C1, C2, P1, P2
		SPDT	5	W1, W2, C1, C2, P1, P2	W2, C1, C2, P1, P2
3	I	NO	6	W2, C1, C2, P1, P2	W2, C1, C2, P1, P2
		NC	6	W2, C1, C2, P1, P2	W2, C1, C2, P1, P2
		SPDT	9	W2, C1, C2, P1, P2	W2, C1, C2, P1, P2
	C	NO	4	W1, W2, C1, C2, P1, P2	W2, C1, C2, P1, P2
		NC	4	W1, W2, C1, C2, P1, P2	W2, C1, C2, P1, P2
		SPDT	7	W2, C1, C2, P1, P2	W2, C1, C2, P1, P2
4	I	NO	8	W2, C1, C2, P1, P2	W2, C1, C2, P1, P2
		NC	8	W2, C1, C2, P1, P2	W2, C1, C2, P1, P2
		SPDT	12	W2, C1, C2, P1, P2	W2
	C	NO	5	W1, W2, C1, C2, P1, P2	W2, C1, C2, P1, P2
		NC	5	W1, W2, C1, C2, P1, P2	W2, C1, C2, P1, P2
		SPDT	9	W2, C1, C2, P1, P2	W2, C1, C2, P1, P2
5	I	NO	10	W2, C1, C2, P1, P2	W2, C1, C2, P1, P2
		NC	10	W2, C1, C2, P1, P2	W2, C1, C2, P1, P2
		SPDT	15	W2	W2
	C	NO	6	W2, C1, C2, P1, P2	W2, C1, C2, P1, P2
		NC	6	W2, C1, C2, P1, P2	W2, C1, C2, P1, P2
		SPDT	11	W2, C1, C2, P1, P2	W2
6	I	NO	12	W2, C1, C2, P1, P2	W2
		NC	12	W2, C1, C2, P1, P2	W2
		SPDT	18	W2	-
	C	NO	7	W2, C1, C2, P1, P2	W2, C1, C2, P1, P2
		NC	7	W2, C1, C2, P1, P2	W2, C1, C2, P1, P2
		SPDT	13	W2	W2

¹⁾ I = Independent and C = Common

²⁾ 2 wires more than standard

Optional: temperature sensor located at the bottom of the rod inside the instrument.

Temperature sensor		
PT1000	EN 60751 – IEC 751	Class A
TRM (Thermostat)	40°C ... 120°C - 10°C step	Precision ± 5% Differential 10°C ± 4°C

BILGE	
Wiring	
Dimensions (mm)	
Ambient temperature	-30 / + 55 °C - 90% RH
Maximum working temperature	105°C
Weight	1,2 Kg
Minimum degree of protection	IP68



Additional information			
Documents	Data sheet	H20041	www.trafag.com/H20041
	Instructions	H21040	www.trafag.com/H21040