



Warning: Before installation, commissioning, and operation, ensure that the Hybrid Gas Density Monitor is suitable for the application in terms of measuring range, design and environmental conditions. Non-observance can result in serious injury and/or damage to equipment. The installation may only be carried out by appropriately trained personnel.

Intended use: This instrument measures the density of gases, in particular of insulation gases in high voltage equipment. In addition, it provides a temperature indication measured inside the device. It combines a gas density monitor with up to three microswitch outputs and an electronic gas density sensor with Modbus RS485 output signal. The instrument has been designed and built solely for the intended use described here and may only be used accordingly. If the equipment is used in a different manner, the protection provided by the equipment may be impaired and Trafag shall not be liable for any claims at all.

The device is designed to be used in an industrial, electromagnetic environment in accordance with: IEC 61326-2-3 / IEC 61326-1 / IEC 61000-6-2 / IEC 61000-6-3

**Datasheet**  
**H72517**



[www.trafag.com/H72517](http://www.trafag.com/H72517)

**Manual**  
**H73517**



[www.trafag.com/H73517](http://www.trafag.com/H73517)

**Software instructions**  
**H73622**



[www.trafag.com/H73622](http://www.trafag.com/H73622)

**Type label description**

Manufacturing date (WW/YY)

Type code (for all inquiries, please indicate this number)

Serial number (for all inquiries, please indicate this number)

Gas / gas mixture for which the instrument is calibrated

Switchpoint settings for the density monitoring outputs

Density sensor power supply and Modbus factory settings and firmware variant code

Operating temperature range

**trafag** Hybrid Density Monitor RS485/Modbus (RTU)  
sensors  controls

QR code

Type 8791.XX.XXXX.XX  
S/N 11111111-001      XX/XX  
SF<sub>6</sub>: 100 %

P1: XXX°C - Contact XX-XX  
P2: XXX°C - Contact XX-XX  
P3: XXX°C - Contact XX-XX

Supply: U<sub>2</sub> + 11...30 VDC      Baudrate: 19200  
Firmware: C-001      Parity: even  
Server ID: 1

Country of origin: Switzerland  
Part No.: 111111111111

QR code

Operating temp.: -40 ... +80°C

## Connection of the device

The wiring terminal is divided into a microswitch block (X1) and a density sensor block (X2).

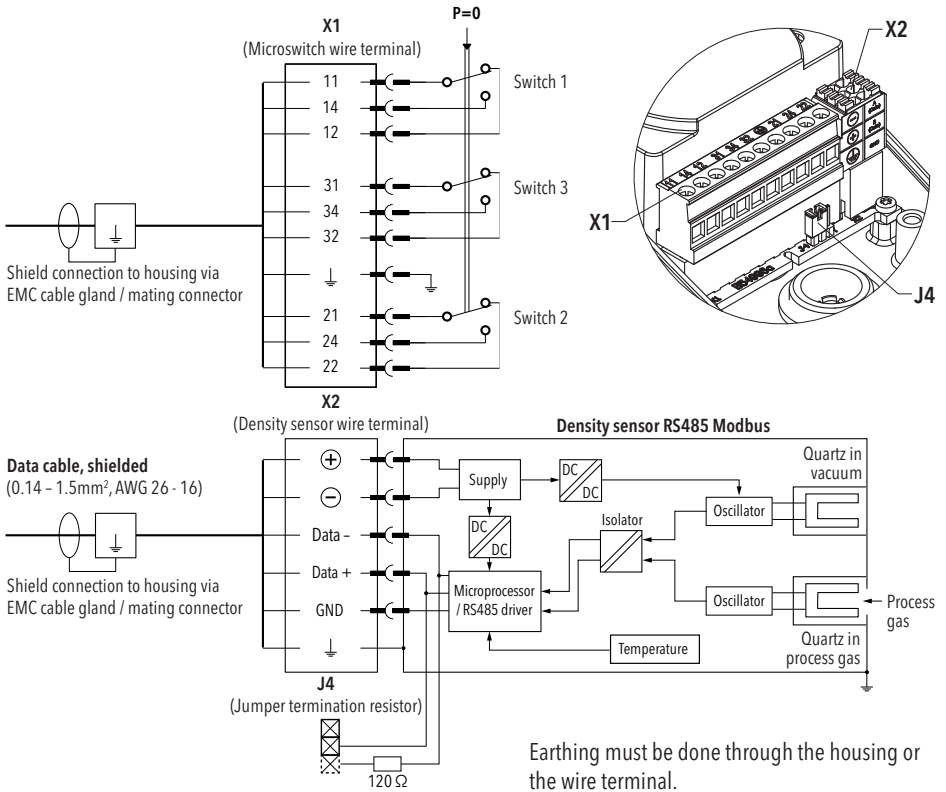

## Initial response time after installation

Transient response time required for signal output to reach accuracy tolerance band:

- Less than 1 h after connecting monitor to pressurised compartment
- Less than 1 min. when monitor is vacuumised together with compartment before gas filling

# Electrical connection of density monitor

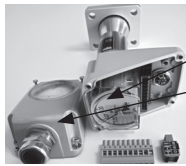

**Parts**  
Density monitor  
Cover



**Inside view**  
Wire terminal  
Sensor wire terminal

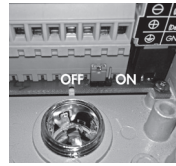

**Termination**  
Jumper Left: off  
Jumper Right: on



**Step 1**  
Remove cover  
Remove terminal block



**Step 2**  
Strip individual conductors according to requirements and insert into the housing



**Step 3**  
Connect individual conductors at appropriate position on terminal block according to customer's specifications



**Step 4**  
Pull back conductors with terminal block



**Step 5**  
Connect terminal block with conductors to density monitor



**Step 6**  
Reposition cover and fasten to housing

## Valve opener



**Important**  
No grease on pressure port  
Grease O-rings only

## Indicator cover



**Important**  
Do not remove indicator cover  
Do not exert pressure on density indicator

## Housing O-Ring



**Wrong**  
Check whether O-ring of housing is correctly positioned in order to ensure seal

## Cable gland



Tightly fasten cable gland by using a wrench

## Correct cable diameter



**Wrong**  
Cable diameter too small to ensure good seal of cable gland



**Correct**  
Cable diameter correct to fit cable gland (good seal)

## Mechanical connection of density monitor (might vary depending on gas connection)



**Step 1**  
Position density monitor properly on valve opener and push-in (insert)



**Step 2**  
Tighten by using a wrench  
Important: Density monitor to be held only at probe (see also next picture)



**Important**  
Avoid holding monitor housing while tightening (see Step 2)  
Do not align monitor by turning the housing  
=> align by turning probe